

E02/E22/E32 Series

Operation Manual



NUMATIC

Specifications:

		E02	E22	E32
Minimum Supply Pressure	Set Pressure	+ 15 PSI (1 BAR)	+ 15 PSI (1 BAR)	+ 15 PSI (1 BAR)
	Standard Pressure:	150 PSI (10 BAR)	150 PSI (10 BAR)	150 PSI (10 BAR)
Maximum Supply Pressure	High Pressure:	190 PSI (13 BAR)	190 PSI (13 BAR)	190 PSI (13 BAR)
	Standard Pressure:	0-100 PSI (0-6.9 BAR)	0-100 PSI (0-6.9 BAR)	0-100 PSI (0-6.9 BAR)
Regulating Pressure Ranges	High Pressure:	0-150 PSI (0-10.2 BAR)	0-150 PSI (0-10.2 BAR)	0-150 PSI (0-10.2 BAR)
	Standard Pressure:	24VDC ±10%	24VDC ±10%	24VDC ±10%
Power Supply	Voltage	0.04 A	0.04 A	0.04 A
	Current Consumption	4-20mA	4-20mA	4-20mA
Input Signal	Current	0-5VDC, 0-10VDC	0-5VDC, 0-10VDC	0-5VDC, 0-10VDC
	Voltage	10 KΩ	10 KΩ	10 KΩ
Input Impedance	0-5 VDC	20 KΩ	20 KΩ	20 KΩ
	0-10 VDC	100 Ω	100 Ω	100 Ω
Output Signal	Analog Output	0-5VDC 0-10VDC 4-20mA	0-5VDC 0-10VDC 4-20mA	0-5VDC 0-10VDC 4-20mA
	Switch Output	24VDC (PNP or NPN)	24VDC (PNP or NPN)	24VDC (PNP or NPN)
Linearity		≤ ±1% of span	≤ ±1% of span	≤ ±1% of span
Hysteresis		≤ ±.5% of span	≤ ±.5% of span	≤ ±.5% of span
Repeatability		≤ ±.5% of span	≤ ±.5% of span	≤ ±.5% of span
Sensitivity		≤ ±.2% of span	≤ ±.2% of span	≤ ±.2% of span
Temp Characteristics		±.5% of span /°C	±.5% of span /°C	±.5% of span /°C
Output Display	Accuracy	±.5% of span	±.5% of span	±.5% of span
	Minimum unit	PSI 0.1, BAR 0.01, kPa 001., kgf/cm ² 0.01	PSI 0.1, BAR 0.01, kPa 001., kgf/cm ² 0.01	PSI 0.1, BAR 0.01, kPa 001., kgf/cm ² 0.01
Temperature Range		40-120°F 4-50°C	40-120°F 4-50°C	40-120°F 4-50°C
Enclosure		IP65 and NEMA 4 Equivalent	IP65 and NEMA 4 Equivalent	IP65 and NEMA 4 Equivalent
Weight		0.68 lbs (0.31kg)	1.4 lbs (0.64kg)	2.34 lbs (1.06kg)

Pin Configuration:

Pin Configuration

Command Signal
Analog Digital

Pin 1 +24VDC

Pin 2 Command Signal Input Signal 1

Pin 3 +0VDC common

Pin 4 Monitor Output Input Signal 2

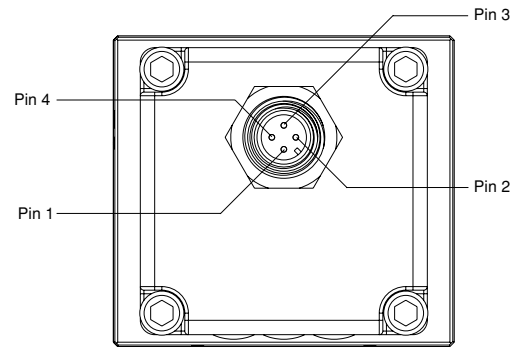

1

2

Dimensions:

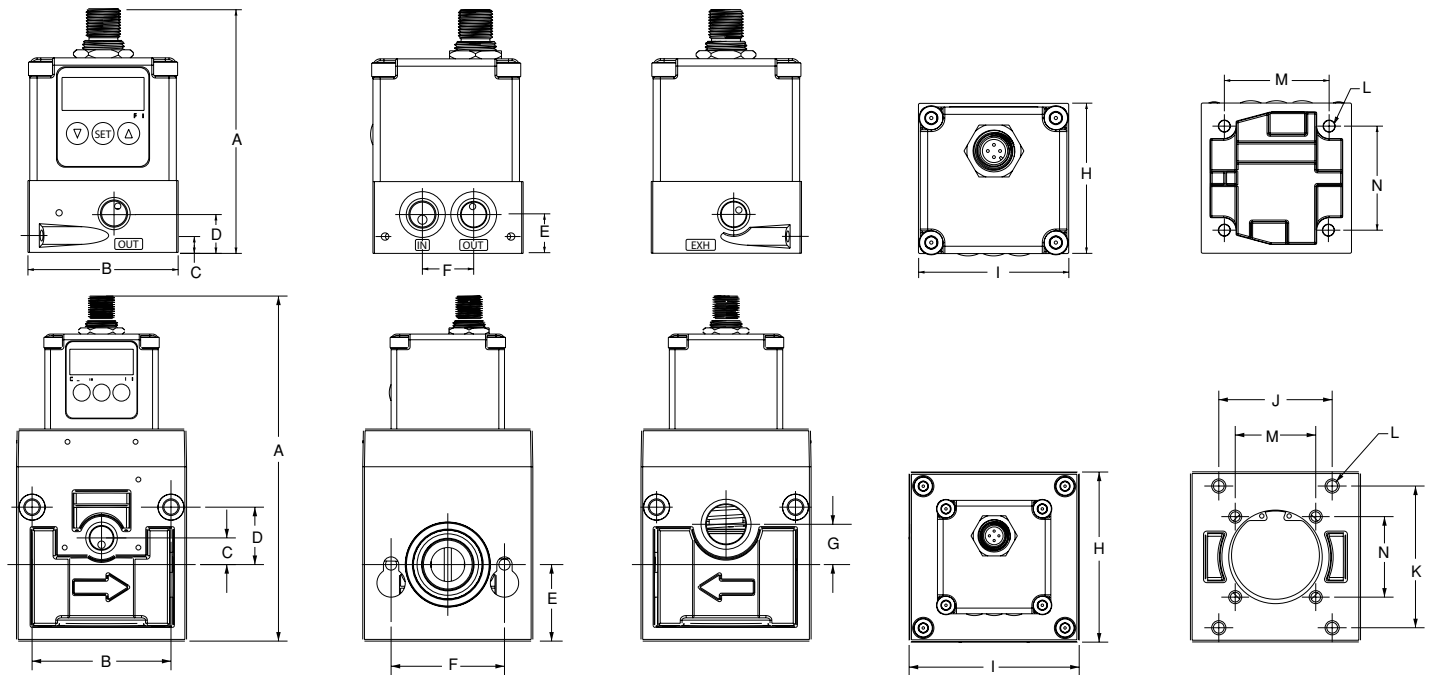

Dimensions	A	B	C	D	E	F	G	H	I	J	K	L	M	N
E02	3.33 (85)	2.05 (52)	0.23 (6)	0.53 (13)	0.53 (13)	0.70 (18)	NA	2.05 (52)	2.05 (52)	NA	NA	0.80 (20)	1.42 (36)	1.42 (36)
E22	5.57 (141)	1.83 (46)	0.29 (7)	.70 (18)	1.00 (25)	1.58 (40)	0.70 (18)	2.17 (55)	2.38 (60)	1.70 (43)	1.80 (46)	0.19 (5)	1.42 (36)	1.42 (36)
E32	6.09 (155)	2.45 (62)	0.47 (12)	1.01 (26)	1.35 (34)	2.00 (51)	0.71 (18)	3.00 (76)	3.00 (76)	2.00 (51)	2.50 (64)	0.19 (5)	1.42 (36)	1.42 (36)

Analog

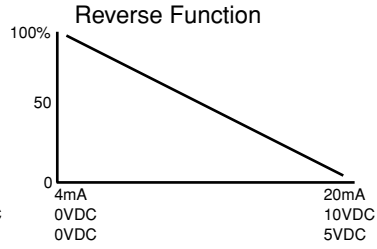
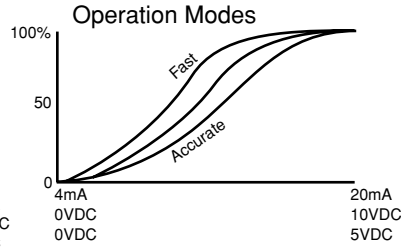
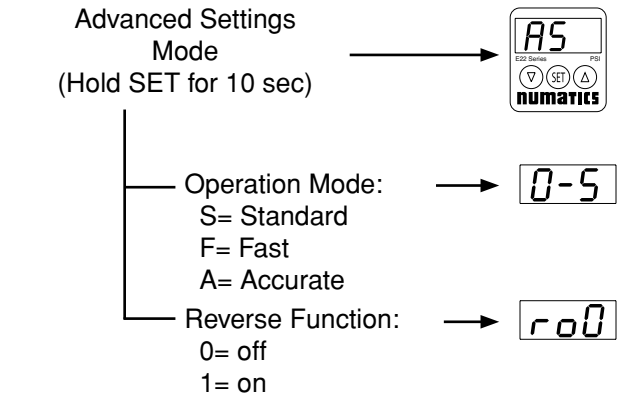
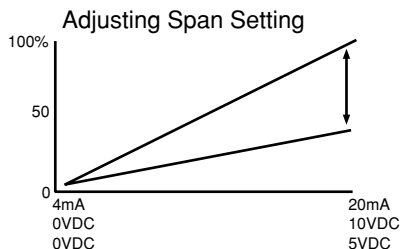
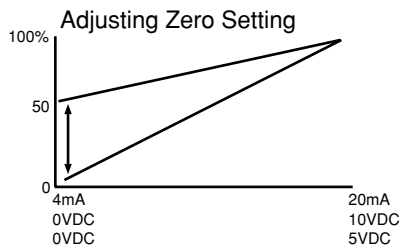
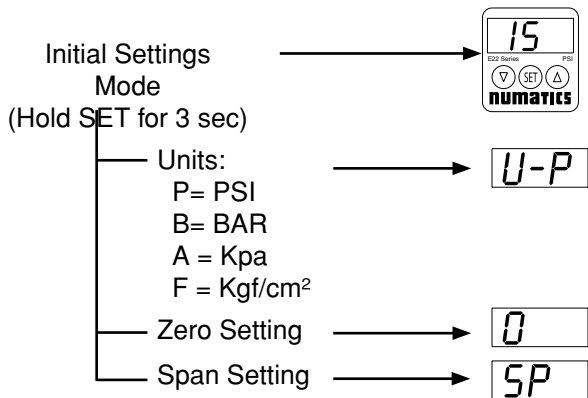

Hold the set button for 3 seconds or until "15" is displayed. Once the set button is released the unit of measure is displayed as "U-P". To select the desired unit, scroll using the up or down arrow buttons. Once the appropriate unit is displayed, press the set button, which prompts the zero setting. This is shown by flashing between a left justified zero and a right justified setting. Use the up or down arrow buttons to select the desired minimum pressure. Press the set button to store the zero setting and prompts the span setting shown by flashing between "SP" and the setting. Use the up or down arrow buttons to select the span setting. Finally press the set button to store the span setting and return to normal operation.

Hold the set button for 10 seconds or until "AS" is displayed. Once the set button is released the operation mode is displayed as "0-5". Use the up or down arrow buttons, to select the optimal operation mode. The best mode will be determined by the application. Generally, the accurate mode should be used when response time is less critical than accuracy and the fast mode should be used when the response time is more critical than accuracy. Press the set button to store the appropriate operation mode and prompts the reverse function, displayed as "r00". Use the up or down arrow buttons to turn the reverse function on or off. Finally, press the set button to store the reverse function and return to normal operation.

Digital

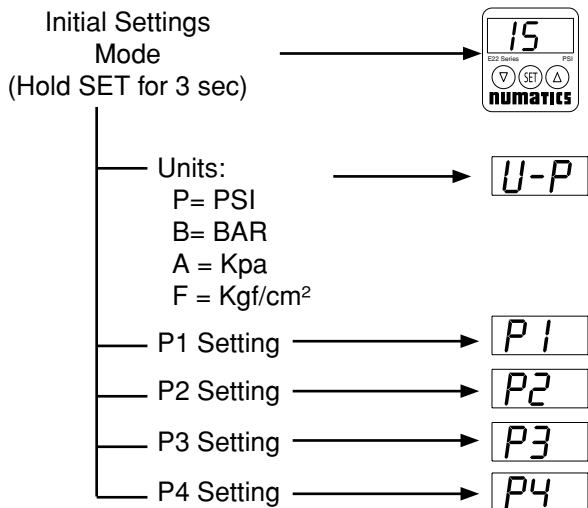

Pressure	P1	P2	P3	P4
Pin 2 Input Signal 1	OFF	ON	OFF	ON
Pin 4 Input Signal 2	OFF	OFF	ON	ON

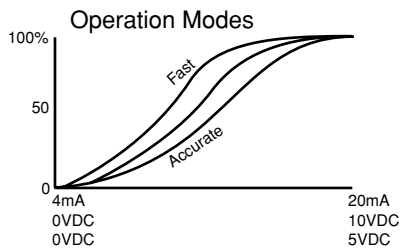
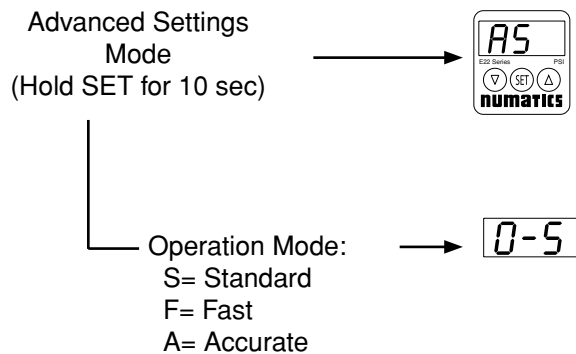

Hold the set button for 3 seconds or until "15" is displayed. Once the set button is released the unit of measure is displayed as "U-P". To select the desired unit, scroll using the up or down arrow buttons. Once the appropriate unit is displayed, press the set button, which prompts the first pressure point settings. The prompt is shown by flashing between a left justified "P1" and the right justified setting. Use the up or down arrow buttons to select the desired pressure set point. Press the set button to store the "P1" setting and prompts the next pressure set point. Use the same procedure to set the remaining three pressure set points. After "P4" is set, pressing the set button will store the setting and return to the normal operation mode.

Hold the set button for 10 seconds or until "AS" is displayed. Once the set button is released the operation mode is displayed as "0-5". Use the up or down arrow buttons, to select the optimal operation mode. The best mode will be determined by the application. Generally, the accurate mode should be used when response time is less critical than accuracy and the fast mode should be used when the response time is more critical than accuracy. Press the set button to store the appropriate operation mode and returns to normal operation.

Locked Mode

Prevents any unintentional changes in the settings

Press and hold the up and down arrow buttons for 10 seconds to activate the locked mode with will be displayed by a "L". To unlock the display, press and hold the up and down arrow buttons for 10 seconds until the "L" is displayed.

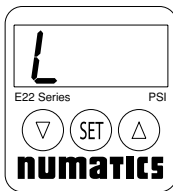

Self-Test Mode

Allows for manual operation without a control signal. Use the up or down arrow keys to change pressures, helps determine the optimal pressure for the application.

Push and hold the SET button before power is applied. Continue to hold the SET button for 3 seconds after power is applied. Push and hold the UP and DOWN buttons for 10 seconds.

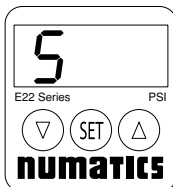

Notes:

1. This product is not intended to be used as a safety device to protect life or prevent injury.
2. Misapplication of this product could result in injury or equipment damage.
3. Supply air must be filtered to 5µ or less and free of moisture and lubricants.
4. Before installation, flush piping to insure that it is free of oil, pipe scale, rust, etc.
5. When using sealing tape, leave 1 ½ or 2 threads bare to prevent contamination.
6. Operating device without supply pressure for prolonged periods of time could result in internal damage.
7. When the monitor output is not used, use proper shielding to protect the contact.
8. Unless otherwise specified, when power is removed from the unit, output pressure will remain at the last commanded pressure, until supply pressure is removed.
9. After the zero setting has been changed, the regulator will output that pressure after pressing the set button, even if there is no command signal present.
10. Disassembling this unit will void all warranties.

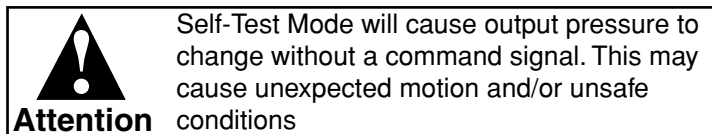

8

Wiring Diagrams:

2 BIT, 4 PRESSURE SELECT WITH PNP INPUTS

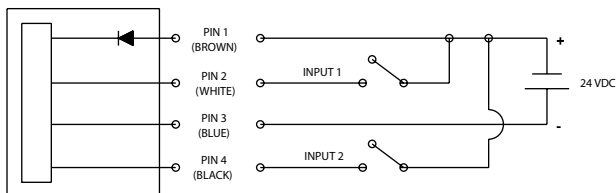

2 BIT, 4 PRESSURE SELECT WITH NPN INPUTS

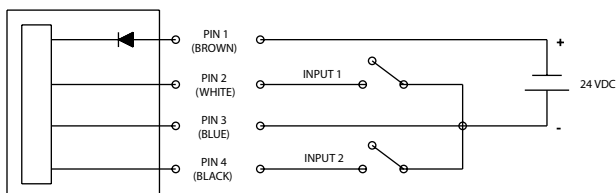

ANALOG INPUTS WITH A PNP OUTPUT

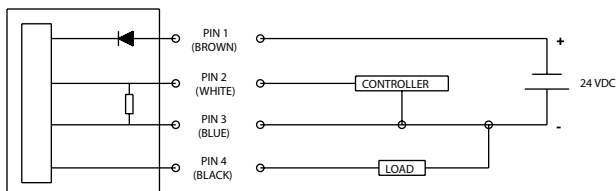

ANALOG INPUTS WITH A NPN OUTPUT

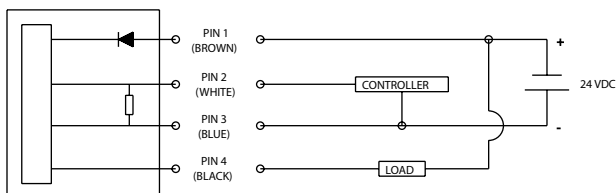

10

9

ANALOG INPUTS WITH ANALOG OUTPUTS

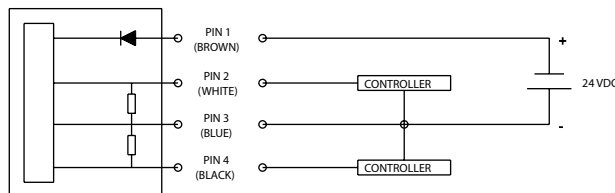

How to Order:

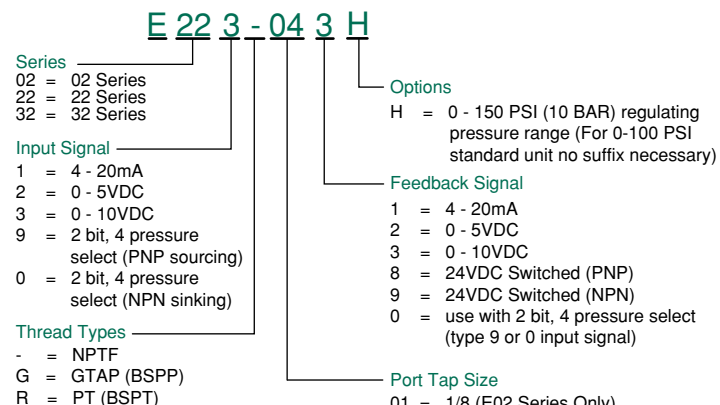

11